



*Gaithersburg*  
A CHARACTER COUNTS! CITY

# DECK PERMIT GUIDELINES



PLANNING AND CODE ADMINISTRATION  
31 SOUTH SUMMIT AVENUE  
GAITHERSBURG, MARYLAND 20877  
(301) 258-6330  
[plancode@gaitersburgmd.gov](mailto:plancode@gaitersburgmd.gov)  
[www.gaitersburgmd.gov](http://www.gaitersburgmd.gov)

# TABLE OF CONTENTS



## THE DECK PERMIT

Application Process.....	1
Contractor's Obligation.....	1
Quality Construction .....	1
Submission Checklist for Deck Permit.....	2



## PLANS

House Location Plat.....	3
Plan View .....	4
Elevation View.....	4



## STRUCTURAL ELEMENTS

Deck Framing .....	5
Framing Connections.....	8
Footings .....	9
Stair Landing Options.....	9
Stair Stringer.....	10
Railings and Guardrails.....	11



## INSPECTIONS

Footing Inspection.....	12
Framing Inspection.....	12
Final Inspection .....	12



## THE DECK PERMIT

This booklet provides the homeowner and the contractor with information on obtaining a deck permit in the City of Gaithersburg. Questions should be referred to the Planning and Code Administration.

### ■ APPLICATION PROCESS

The first step in the process is to obtain the deck permit guidelines and application from the Planning and Code Administration located at City Hall. It is important that the applicant do this before beginning any construction because building and zoning codes differ between jurisdictions and periodically change. Work completed prior to a plan review by the City may not meet City Code and may need to be redone.

The details of the deck design should be prepared following the guidelines for plan drawings and structural elements that are provided in this booklet.

The next step is to get the approval for the deck from other required regulatory bodies, such as a homeowners' association. Most homeowners' associations have their own deck standards and provide letters of approval to be submitted to the City. Some decks will need a variance from the City Board of Appeals if they do not meet required setbacks, and others may require a historic area work permit from the Historic District Commission if the site is historic.

The final step is the submission of the **complete** application, with the appropriate fee and requirements listed on page 2, to the Department of Planning and Code Administration. The plans are forwarded to a plans examiner for review, and after the permit is ready, the applicant is contacted by phone.

### ■ CONTRACTOR'S OBLIGATION

If a contractor will be building the deck, the application must be signed by the contractor and include a copy of the builder's Maryland Home Improvement Commission License. Complex or nonstandard designs may require the stamp of a Maryland registered engineer or architect.

### ■ QUALITY OF CONSTRUCTION

Although safety is the primary concern, the structural design, workmanship, and quality of construction materials are all subject to review by the City's construction field inspectors. Field changes to permit drawings must be approved before including the changes in the construction. Any other conditions placed on the permit must also be met.

## ■ SUBMISSION CHECKLIST FOR DECK PERMIT

The complete application should include the following:

- Application for Deck Permit
- Application Fee
- Copy of Maryland Home Improvement Commission License (if applicable)
- House Location Plat with deck drawn to scale (2 copies)
- Letter of Approval from Homeowners' Association/Condominium Association (if applicable)
- Letter of Approval from Town Architect (Kentlands residents only)
- Historic Area Work Permit (if applicable)
- Board of Appeals Resolution (if applicable)
- Plan drawings (two sets)
  - Elevations
  - Plan View

### **Plans should include:**

- Overall deck size
- Beam size and spacing
- Spacing between house and beam
- Post size and spacing
- Height of deck above grade
- Joist size and spacing
- Joist connection to ledger and beam
- Footing size, depth and method (see example)
- Ledger attachment to house
- Bolt size, types and spacing
  - at house
  - at post/beam
  - at guardrail
- Nail types (i.e., galvanized)
- Size and type of decking
- Size and spacing of guardrail posts
- Size, type and spacing of guardrail pickets or enclosures
- Height of guardrail
- Size of guardrail top
- Cantilever length (beam overhang past post)
- Cantilever length (joist overhang past beam)
- Post/beam connection
- Type wood (e.g., pressure treated wood, approved hard wood)



## PLANS

Required materials to be submitted with the application include a copy of the house location plat and 2 sets of actual working drawings. Samples follow.

### ■ HOUSE LOCATION PLAT

An example of a house location plat is shown below. This plat is usually included with settlement documents received at the time the house is purchased. Copies of a house location plat can also be obtained from the Montgomery County Land Records Office in Rockville.

The deck must be drawn **to scale** on the house location plat, and **preferably in red**. Decks may not be built over easements and are subject to certain setback requirements. Should the deck encroach into a setback or required yard restriction, it will need a variance and the review of the Board of Appeals.

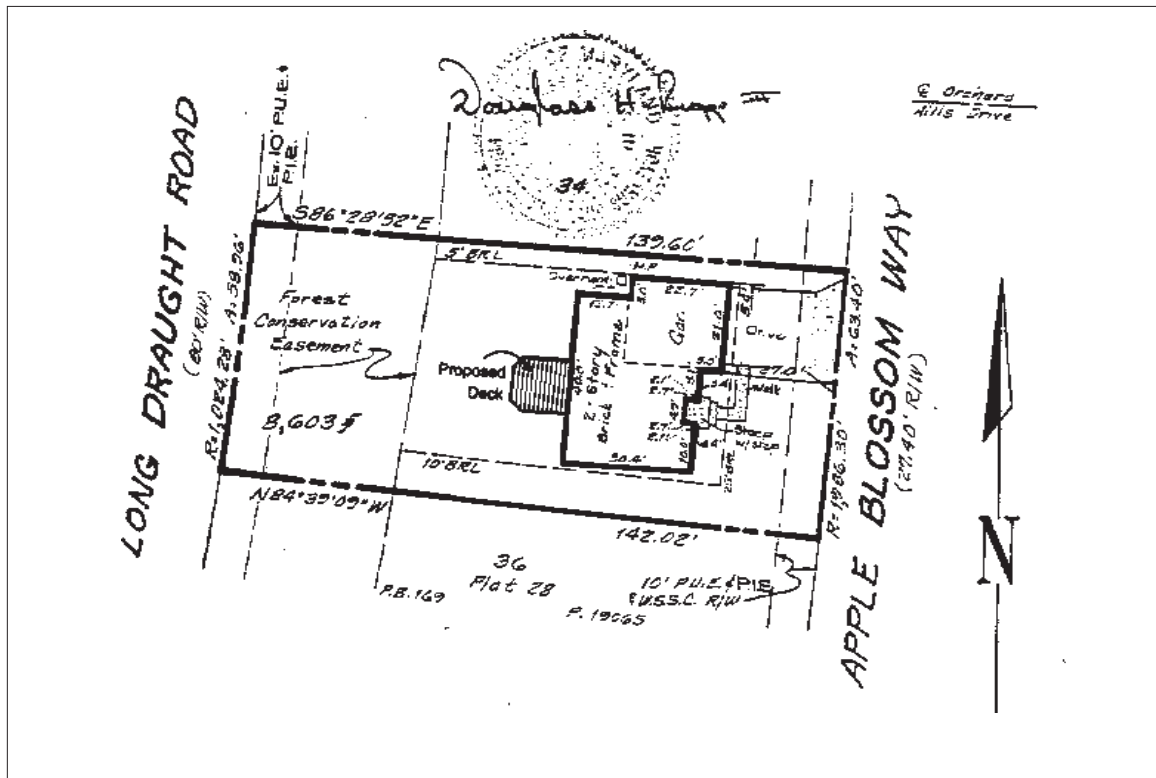

HOUSE LOCATION PLAT SAMPLE

■ **PLAN VIEW**  
SAMPLE

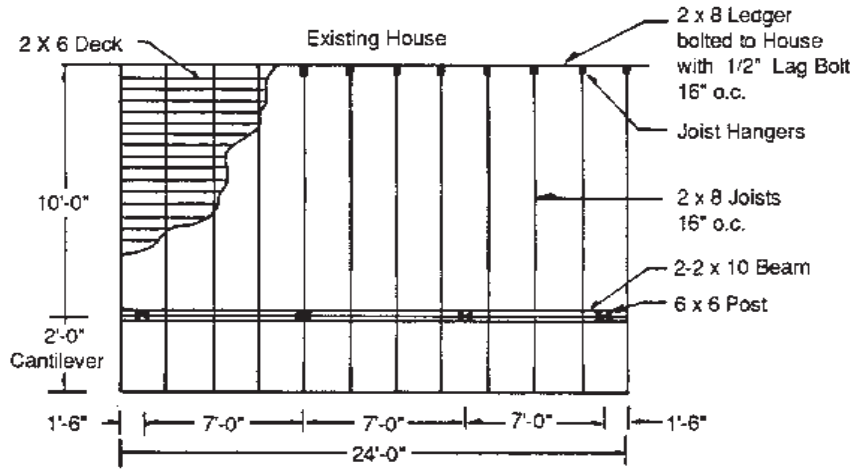

■ **ELEVATION VIEW**  
SAMPLE

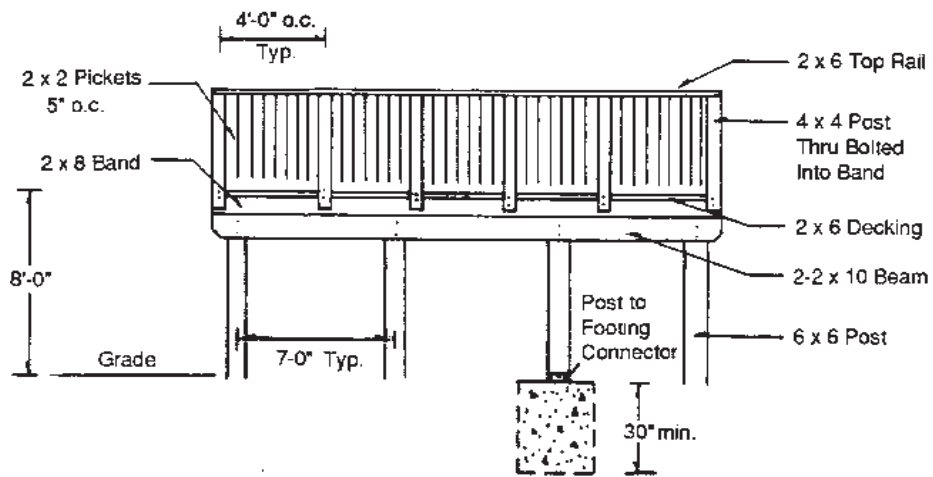

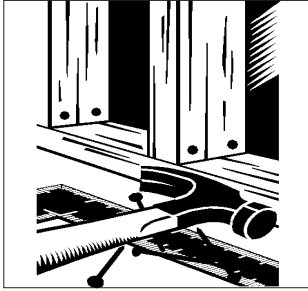

## STRUCTURAL ELEMENTS

Detailed working drawings must be submitted with the application. The following pages provide guidelines for determining the size of structural elements. The checklist on page two identifies the details which should be included on the drawings to assure an accurate submission. Any questions should be referred to the Department of Planning and Code Administration.

*Decks constructed according to this handout are not approved for future hot tub installations.*

### ■ DECK FRAMING

MAXIMUM SPANS FOR DECK JOISTS

Joist Size (inches)	Joist Spacing (inches)		
	12"	16"	24"
2 x 6	9' - 3"	8' - 0"	6' - 6"
2 x 8	12' - 3"	10' - 7"	8' - 8"
2 x 10	15' - 7"	13' - 6"	11' - 0"
2 x 12	18' - 0"	16' - 5"	13' - 5"

Note: (1) Above table is based on 60 pounds per square foot live load plus 10 pounds per square foot dead load.  
 (2) Lumber grade is Southern Pine No. 2 or better, 1 percent moisture content.

#### ***Maximum Joist Cantilever***

If joists are at maximum span, use 3:1 ratio to determine allowable cantilever; i.e., for every 3 feet out from the house, the cantilever length is 1 foot. The maximum cantilever cannot exceed 4 feet.

## BEAM LOADING AND POST SPACING

Beam Size (inches)	Beam Loading (L)													Max. Beam Cantilever
	4	5	6	7	8	9	10	11	12	13	14	15	16	
	Maximum Post Spacing (feet)													
2 - 2 x 6	5	5	5	4	4	4	4	4	4	4	4	4	4	1' - 0"
3 - 2 x 6	7	7	6	6	5	5	5	4	4	4	4	4	4	1' - 3"
2 - 2 x 8	7	7	7	6	6	5	5	5	4	4	4	4	4	1' - 8"
3 - 2 x 8	9	9	8	8	7	7	6	6	6	5	5	5	5	2' - 0"
2 - 2 x 10	9	9	9	8	7	7	6	6	5	5	5	4	4	2' - 0"
3 - 2 x 10	11	11	11	9	9	9	8	8	7	7	7	6	6	2' - 6"
2 - 2 x 12	11	11	10	10	8	8	8	7	7	6	6	5	5	2' - 6"
3 - 2 x 12	13	13	13	11	11	10	10	9	9	9	8	8	8	3' - 0"
4 - 2 x 6	8	8	7	7	6	6	5	5	5	5	4	4	4	1' - 6"
4 - 2 x 8	10	10	9	9	8	8	7	7	7	6	6	6	6	2' - 3"
4 - 2 x 10	12	12	12	11	11	10	9	9	8	8	8	7	7	2' - 3"
4 - 2 x 10	14	14	14	13	13	12	12	12	12	10	10	9	9	3' - 0"

### TO DETERMINE BEAM LOADING AND POST SPACING

#### 1. Single Beam Deck

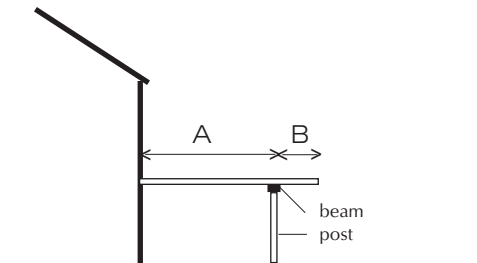

To find beam loading (L) for a single beam deck, divide the distance A (house to middle of beam) by 2 and add the length of the cantilever.

$$L = \left( \frac{\text{A}}{2} \right) + \text{B}$$

beam loading
house to beam
÷ 2
+
cantilever

Example: If A = 10 feet and B = 2 feet, then L = 7.  
 $(10 \div 2) + 2 = 7$

To find post spacing refer to BEAM LOADING AND POST SPACING table.

Example: If plans call for 2 - 2 x 10 beam, and L = 7, then the post spacing is a maximum of 8 feet.

## 2. Double Beam Deck

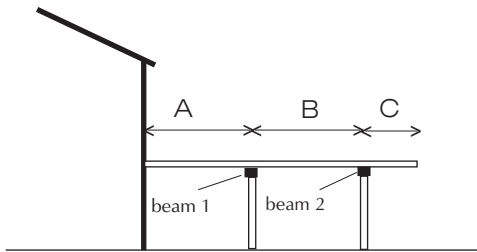

### BEAM 1

**To find beam loading (L)** for beam 1, add the distances A (house to center of beam 1) and B (beam 1 to beam 2) and divide by 2.

$$L = \left( \frac{\text{house to beam}}{A} + \frac{\text{beam to beam}}{B} \right) \div 2$$

Example: If A = 6 feet and B = 8 feet, then beam loading L = 7.  
 $(6 + 8) \div 2 = 7$

**To find beam spacing** refer to BEAM LOADING AND POST SPACING table.

Examples: If plans call for a 2 - 2 x 8 beam, and L = 7, then post spacing is a maximum of 6 feet.  
 If the beam is 2 - 2 x 10, and L = 7, then post spacing is a maximum of 8 feet.

### BEAM 2

**To find beam loading (L)** for beam 2, divide the distance B (beam1 to beam 2) by 2 and add the length of the cantilever (C).

$$L = \left( \frac{\text{beam to beam}}{B} \div 2 \right) + \frac{\text{cantilever}}{C}$$

Example: If B = 8 feet and C = 2 feet, then beam loading L = 6.  
 $(8 \div 2) + 2 = 6$

**To find post spacing** refer to BEAM LOADING AND POST SPACING table.

Examples: If plans call for a 2 - 2 x 8 beam, and L = 6, then the post spacing for beam B is a maximum of 7 feet.  
 If the beam is 2 - 2 x 10, and L = 6, then post spacing for beam B is a maximum of 9 feet.

## ■ FRAMING CONNECTIONS

### POST/BEAM CONNECTION

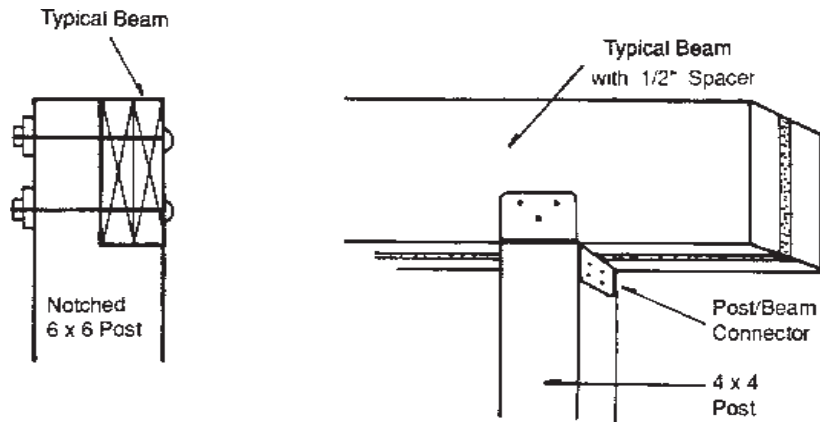

### JOIST/LEDGER CONNECTION

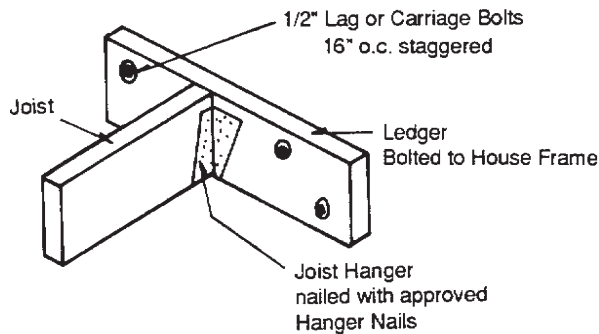

### ATTACHMENT OF THE DECK TO THE HOUSE

Decks may not be attached to house cantilevers, bay windows, or chimneys, and must be securely fastened to structural components of the house. When attaching a deck to a house with manufactured wood joist or plywood band board, solid wood blocking must be installed behind the band board and the deck fastened with 1/2" carriage bolts through this blocking. If the house floor framing cannot be determined or if the band board is not accessible the deck shall be self supported.

### FLASHING

Flashing shall be installed where the deck attaches to a wall or floor system.

Note: The new ACQ (Alkaline Copper Quaternary) pressure treated lumber shall not be in contact with any materials made from or containing aluminum. Fasteners shall be in accordance with Section 323.3 of the 2000 IRC (International Residential Code).

### HEADERS

Deck framing around a bay window or chimney will require the use of a header beam. Headers must be doubled and attached to double joists with approved heavy duty beam hangers. In general, properly constructed headers may span six feet unsupported by posts.

## ■ FOOTINGS

### MAIN DECK FOOTINGS

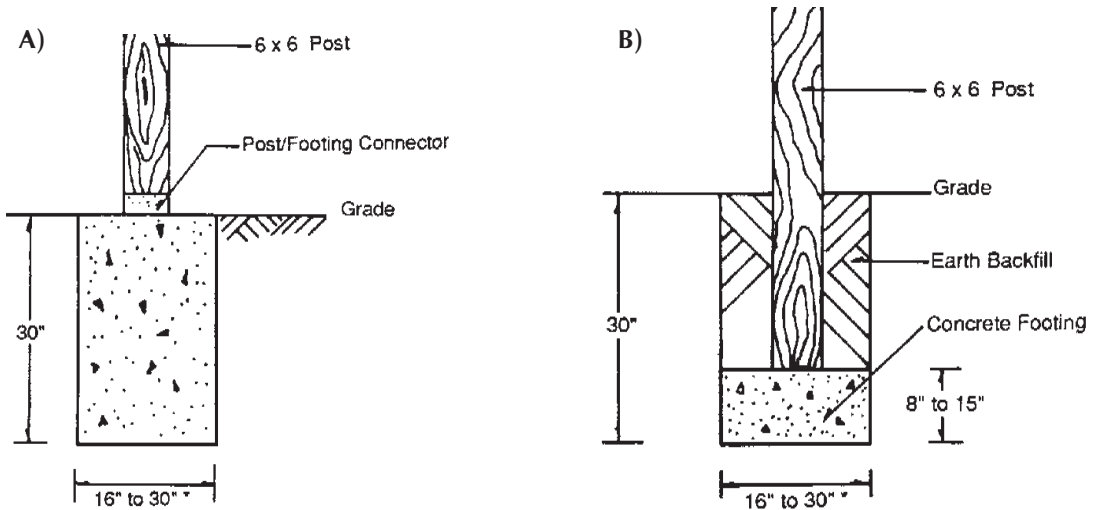

\* Footing width dependent on deck design.

### LANDING AND STAIR FOOTINGS

Landing and stair footings may be reduced to 12" x 12" x 8".

## ■ STAIR LANDING OPTIONS

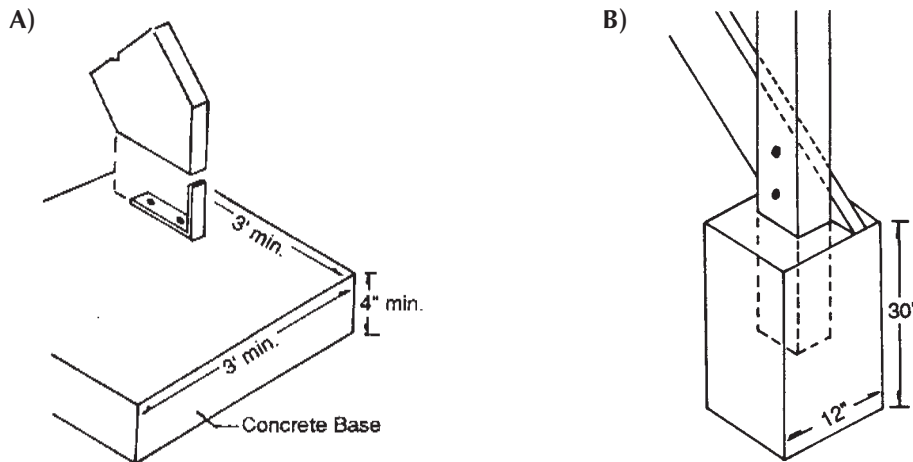

Attach stringer to concrete landing as shown or set stringer into cement.

Set bottom handrail post into 12" x 30" footer.

## ■ STAIR STRINGER

### DIMENSIONS AND DESIGN OPTIONS

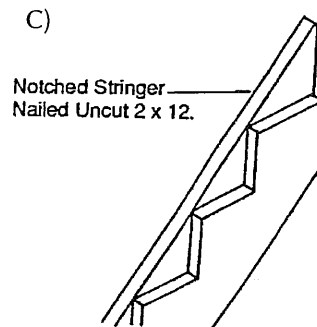
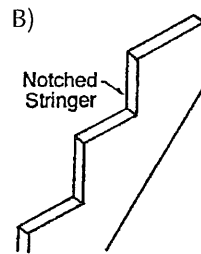
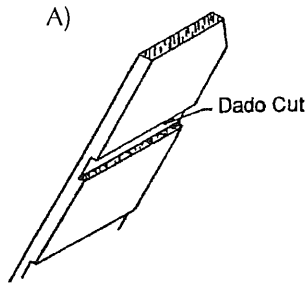
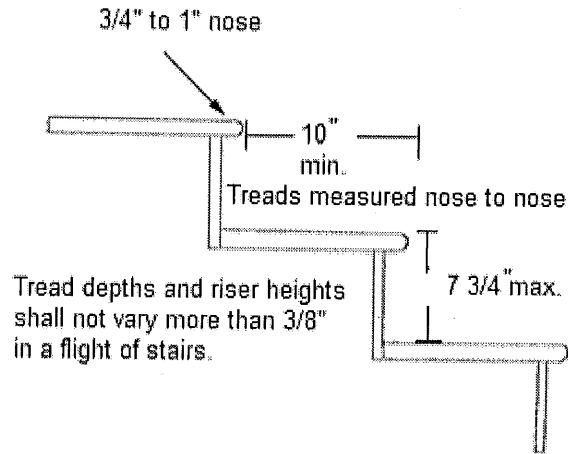

This method eliminates need for intermediate posts on 3-foot wide stairs to second story decks.

### ATTACHMENT TO DECK OPTIONS

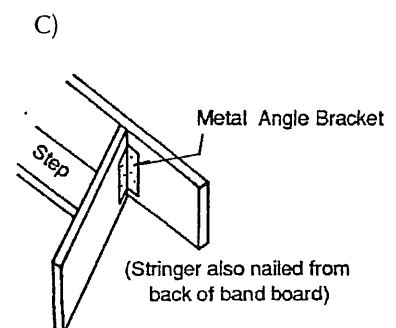
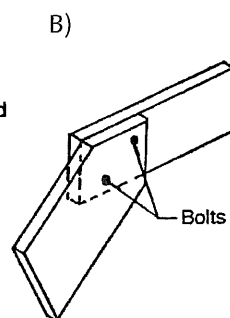
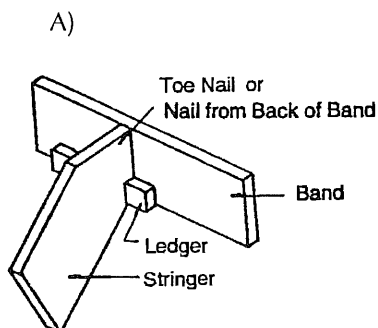

■ RAILINGS AND GUARDRAILS

Handrails shall be installed on stairs with three or more risers. The handrail height shall be between 30 and 38 inches measured vertically from the nose of the treads. Handrails shall be graspable with a cross section dimension of 1 1/4 inches to 2 inches.

Guardrails are required on decks constructed 30 inches or more above grade. The required guardrail height is 36 inches measured from the floor of the deck. Openings in the rails should not allow the passage of a 4-inch or larger diameter object. Guardrails shall be constructed to withstand a 200-pound horizontal load. Lattice and other similar designs may not be able to withstand a 200-pound load and may be subject to evaluation by an engineer hired by the permit applicant. Guardrails shall not have an ornamental pattern that would provide a ladder effect.

Open sides of stairs 30 inches or greater from grade shall have a guardrail not less than 34 inches in height measured vertically from the nosing of the stairs. A graspable handrail is required in addition to the guardrail.

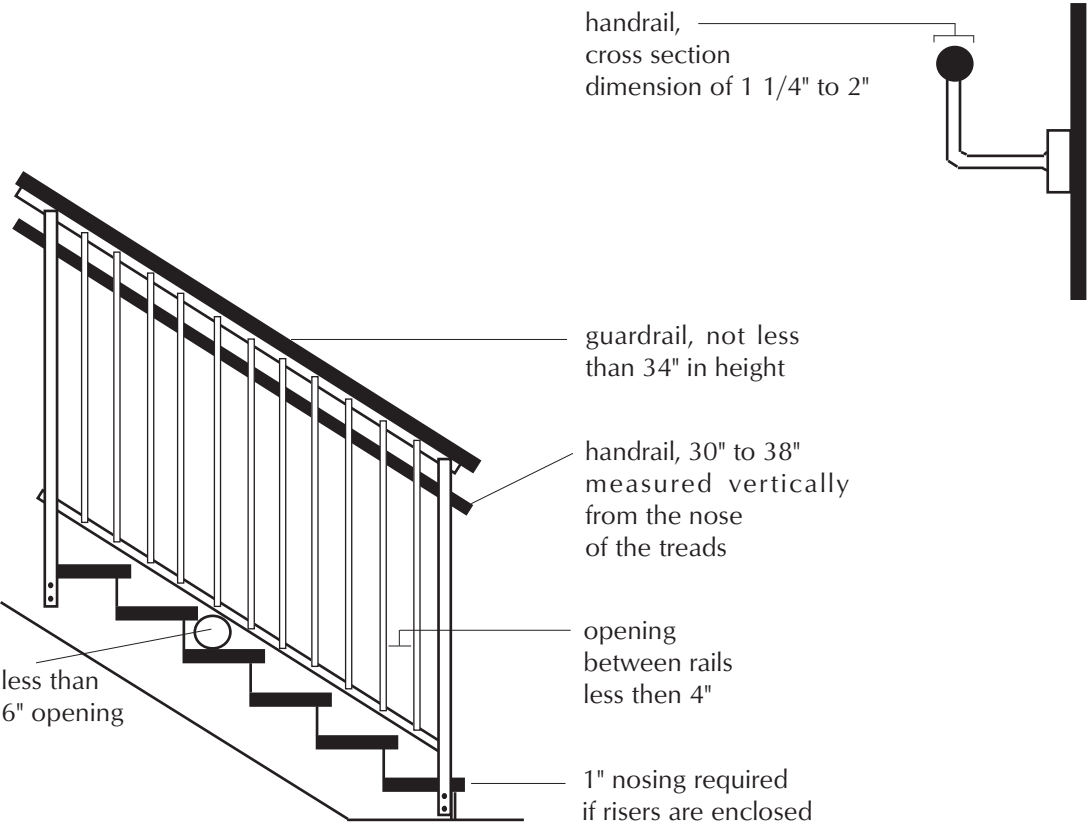

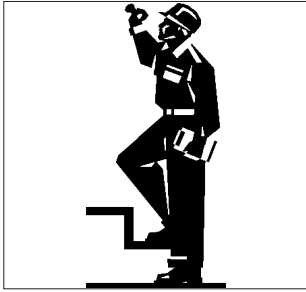

## INSPECTIONS

Inspections are a very important part of the building permit process. It is the responsibility of the permit applicant to ensure that the inspections have been requested and approval obtained from the City inspector at each stage of the project.

### ■ FOOTING INSPECTIONS

This inspection should be done **after** the footings have been excavated and **prior** to placement of concrete.

### ■ FRAMING INSPECTIONS

This inspection is required only if the deck is less than 3 feet above the ground. It should be done **after** the beam(s) and joists are completed, but **before** the decking is installed. The inspector will verify conformance with plans and applicable codes.

### ■ FINAL INSPECTION

This inspection is made **after** the entire deck is completed. If the permit expires before this inspection is conducted, the applicant will be required to pay an additional new permit fee.

Note: Should the complexity of the design require additional inspections not indicated above, the plans examiner will note such on the applicant's permit.



Inspections may be scheduled by calling 301-258-6338 which is in service 24 hours a day. Inspections requested before 6 p.m. will be scheduled for the next business day.

REMEMBER TO CALL MISS UTILITY BEFORE YOU DIG  
1-800-257-7777

**CITY OFFICIALS**  
**July 2010**

Mayor  
Sidney A. Katz

Council Vice President:  
Cathy C. Drzyzgula

Council Members:  
Jud Ashman  
Henry F. Marraffa, Jr.  
Michael A. Sesma  
Ryan Spiegel

City Manager  
Angel L. Jones

**DECK PERMIT GUIDELINES**

**Published:**  
March 1995

**Revised:**  
November 2002  
April 2004  
May 2006  
July 2010

**Publication Team:**  
Wes Burnette, Greg Dennison, Patricia Patula and Maria Fullerton.